

ICREN-01/2013 February 16-17, 2013 Constantine, Algeria First International Conference on Renewable Energies and Nanotechnology impact on Medicine and Ecology

Building Model of Photovoltaic Cell/Module With Matlab/Simulink

L. Rachedi ^a, C.Fetha ^b, T Bahi ^c; a*

^{a,b}*Department of Electronic, Engineering Science Faculty, Hadj Lakhdar University, Batna, Algeria*

^c*Department of Electrotechnic Engineering Science Faculty, Badji Mokhtar university, Annaba, Algeria*

Abstract

In this paper a photovoltaic (PV) module in renewable energy conversion system is simulated. The simulation of the system is developed using MATLAB/Simulink environments, which can be representative of PV cell, module, and array for easy use on simulation block. The PV model is developed using basic circuit equations of the photovoltaic solar cells including the effects of irradiation and temperature. The output current and power characteristics of PV model are simulated. The results are provided and presented here.

Keywords: photovoltaic model; developed; simulation; MATLAB.

1. Introduction

Photovoltaic offer consumers the ability to generate electricity in a clean, quiet and reliable way. Photovoltaic systems are comprised of photovoltaic cells, devices that convert light energy directly into electricity. Because the source of light is usually the sun, they are often called solar cells. The word photovoltaic comes from “photo”, meaning light, and “voltaic”, which refers to producing electricity. Therefore, the photovoltaic process is “producing electricity directly from sunlight”. Photovoltaic are often referred to as PV. The PV cells convert sunlight directly into electricity without creating any air or water pollution. PV cells are made of at least two layers of semiconductor material. One layer has a positive charge, the other negative. When light enters the cell, some of the photons from the light are absorbed by the semiconductor atoms, freeing electrons from the cell’s negative layer to flow through an external circuit and back into the positive layer. This flow of electrons produces electric current.

* Corresponding author. Tel.: 0770965794/0552170192.

E-mail address: nouflot@yahoo.fr.

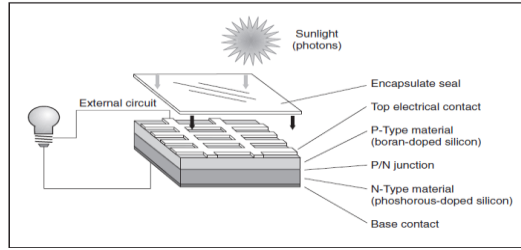

Fig. 1: Basic solar cell construction

A single PV cell being too small for practical power application is usually connected as series-parallel combination to give a required voltage and current in so called PV module. This PV module forms a series-parallel combination to work as PV array. The PV system application can be as grid connected, stand alone or hybrid [1]. The nonlinear PV array characteristic which varies focus with temperature and solar intensity.

2. PV cell model

2.1. Ideal PV cell

The standard PV cell is represented as a current source in parallel with a single diode. The equivalent circuit diagram is shown in Fig. 1. The output, I_{ph} is directly proportional to amount of solar incident on the PV cell.

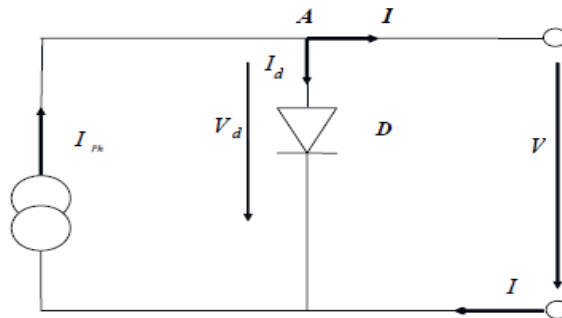

Fig.2. Single-diode model of the theoretical PV cell

$$I = I_{ph} - I_0 (e^{qV/aKT} - 1) \quad (1)$$

With,

$$I_d = I_0 (e^{q(V)/aKT} - 1) \quad (2)$$

Where I_d is the Shockley diode equation, I_0 is the reverse saturation or leakage current of the diode, q is the electron charge ($1.60217646 \times 10^{-19}$ C), k is the Boltzmann constant ($1.3806503 \times 10^{-23}$ J/K), T (in Kelvin) is the temperature of the $p-n$ junction, and a is the diode ideality constant. Fig. 5 shows the $I-V$ curve originated.

2.2. PV Module(Array)

The basic equation (1) of the elementary PV cell does not represent the $I-V$ characteristic of a practical PV module. Practical module is composed of several connected PV cells and the observation of the characteristics at the terminals of the PV. The complete model of PV module should include the effect due to series-parallel combination of each PV [3].

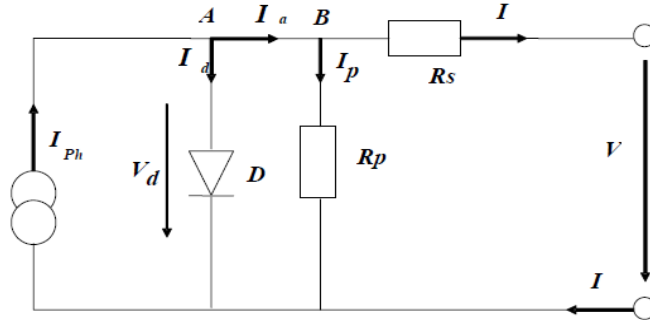

Fig.3. Equivalent circuit of a practical PV device including the series and parallel resistors.

Thus the above equation is expressed as:

$$I = I_{ph} - I_0 \left(e^{q(V+IR_S)/aV_t} - 1 \right) - \frac{(V+IR_S)}{R_{sh}} \quad (3)$$

Where I_{ph} and I_0 are the photovoltaic (PV) and saturation currents, respectively, of the array and $V_t = N_s kT/q$ is the thermal voltage of the array with N_s cells connected in series. Cells connected in parallel increase the current and cells connected in series provide greater output voltages. If the array is composed of N_p parallel connections of cells the PV and saturation currents may be expressed as $I_{ph} = I_{ph,cell} N_p$, $I_0 = I_{0,cell} N_p$. In (3), R_s is the equivalent series resistance of the array and R_p is the equivalent parallel resistance. This equation originates the $I-V$ curve in Fig. 4, where three remarkable points are highlighted: short circuit ($0, I_{sc}$), MPP (V_{mpp}, I_{mpp}), and open circuit ($V_{oc}, 0$) [2].

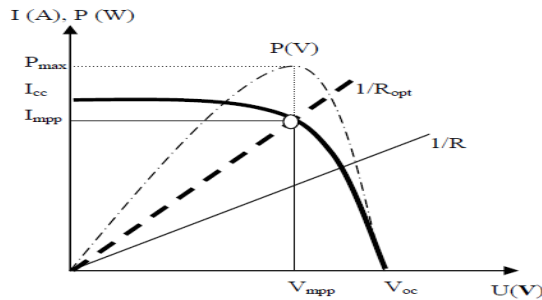

Fig. 4. Current-voltage curve for photovoltaic cells

3. Building of PV model

A model of PV module with moderate complexity which includes the temperature independence of the photocurrent source, the saturation current of the diode, and a series resistance is considered based on the Shockley diode equation. It is important to build a generalized model suitable for all of the PV cell, module, and array, which is used to design and analyze a maximum power point tracker. Being illuminated with radiation of sunlight, PV cell converts part of the photovoltaic potential directly into electricity with both I-V and P-V output characteristics. A generalized PV model is built using Matlab/Simulink [4]-[6] to illustrate and verify the nonlinear I-V and P-V output characteristics of PV module.

3.1. Building of ideal PV cell

The simulation model makes use of basic circuit equations of PV solar cell based on its behavior (1). The Fig. 5 is simulated for obtaining PV cell characteristics and simulation result is shown in Fig. 6.

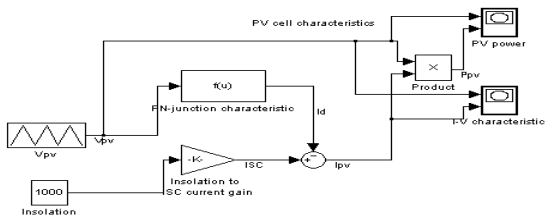

Fig.5. Model of Ideal PV cell in SIMULINK

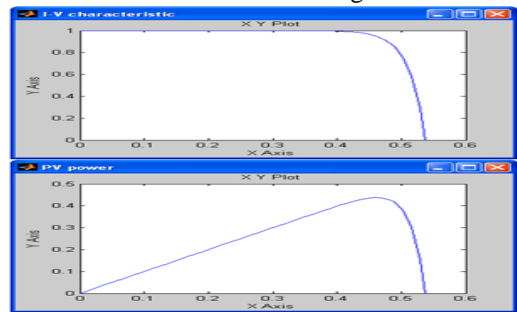

Fig.6. The $i = f(v)$ and $P = f(v)$ characteristics of PV cell

3.2. Building of PV Module (Array)

For a PV module with I-V and P-V output characteristics of generalized PV model for a cell are shown in Fig.7. The nonlinear nature of PV cell is apparent as shown in the Fig.8; the output current and power of PV module depend on the cell's terminal operating voltage, temperature and solar isolation as well.

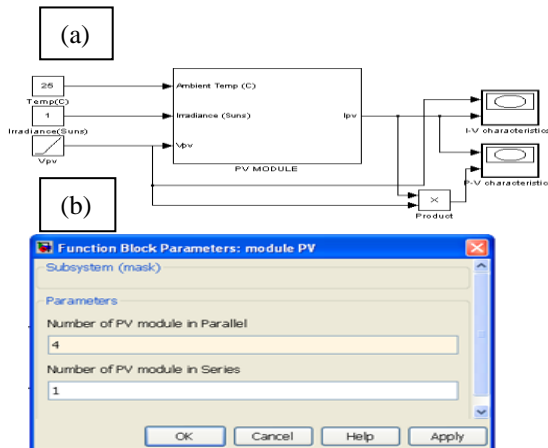

Fig.7: (a) Model of PV module in SIMULINK. (b) Mask implementation of PV module.

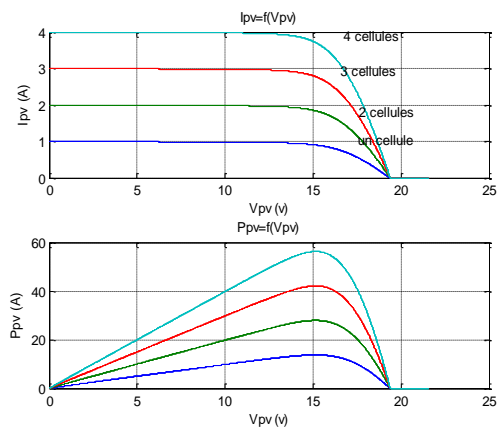

Fig.8. $i = f(v)$ and $P = f(v)$ characteristics

The properties of the group of cells are parallel to those of the dual group in series. Thus, in an array of cells connected in parallel, the cells are subjected to the same voltage and the resultant characteristic grouping is obtained by adding the currents given voltage [7].

4. PV module characteristics

The parameters that determine the operation of a photovoltaic panel reflected in their characteristic curves, I - V and P - V . Fig. 7 shows that modeling of a photovoltaic panel. Fig.9 and Fig.10 represents that the calculation of two groups of curves, first the temperature stayed constant at 25 °C varying the different irradiance (0, 25, 0, 50, 0, 75 and 1sun) generating a type of curves. Later, the irradiance is maintained constant at 1sun calculating the curve for different temperatures (0, 25, 50 and 75 °C)[9]-[11].

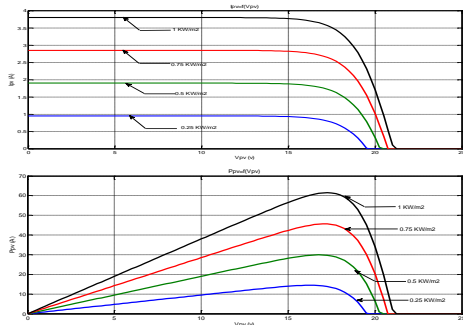

Fig .9: Simulink model I-V and P-V curves for various irradiation Levels ($G=0.25, 0.5, 0.75, 1$ Sun, $T=25^{\circ}\text{C}$)

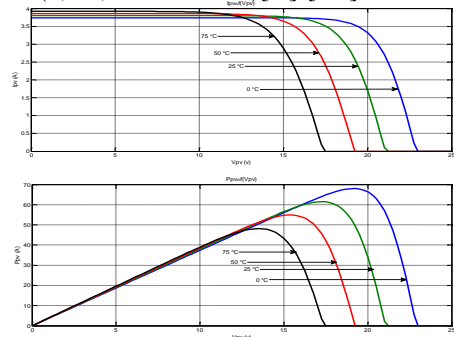

Fig.10: Simulink model I-V and P-V curves for various temperatures. ($G=1$ Sun, $T=0, 25, 50, 75^{\circ}\text{C}$)

From the simulation result it can be observed that as solar radiation falling on PV module is reduced, both I_{sc} and V_{oc} decreases, but the change in V_{oc} is not as prominent with incident solar radiation as is with I_{sc} , which varies almost directly proportional.

To study the effect of temperature variation on PV module output, temperature is taken as one of the variable in addition to the voltage. I - V characteristics and power curves as shown in Fig.10 .It can be observed the saturation current of diode of PV module is highly temperature dependent and it Increases with increase in temperature.

5. Maximum power point tracking

The output power of the solar PV module changes with change in direction of the sun, change in solar isolation level and change in temperature. Also there is a single maximum power point in the PV characteristics of the PV module for a particular operating condition. It is desired that the PV module operates close to this point, output of the PV module approaches near to MPP. The process of operating PV module at this condition is called as maximum power point tracking (MPPT). Maximization of PV power improves the utilization of the solar PV module [12]. The algorithm basis is the PV array output which is constantly adjusted to reach the voltage in the maximum power point (MPP). The Algorithm is implemented using M-file in MATLAB.

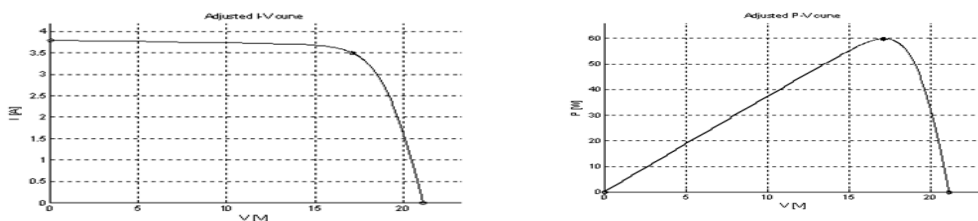

Fig. 11 Module voltage and current at the maximum power

The peak value of the product of V and I represent the maximum power point (MPP) of the solar module. The current and voltage of PV module at the MPP are denoted by I_{mp} and V_{mp} , respectively. The solar module should always be operated in this region so as to extract the maximum power for a given input conditions. For this purpose various power maximum point algorithms can be used.

6. Conclusions

A generalized PV model which is representative of the all PV cell, module, has been developed with Matlab/Simulink and been verified with a PV cell and PV module. The proposed model takes sunlight irradiance and cell temperature as input parameters and outputs the I-V and P-V characteristics under various conditions. This model has also been designed in the form of Simulink block libraries. The masked icon makes the block model easily configure the PV model. Such a generalized PV model is easy to be used for the implementation on Matlab/Simulink modeling and simulation platform. Especially, in the context of the SimPowerSystem tool, there is now a generalized PV model which can be used for the model and analysis in the field of solar PV power conversion system.

References

- [1] Kashif Ishaque, Zainal Salam, and Hamed Taheri :Accurate MATLAB Simulink PV System Simulator Based on a Two-Diode Model. *Universiti Teknologi Malaysia*, Johor, Malaysia.JPE 11-2-9.
- [2] S. Rustemli, F. Dincer:Modeling of Photovoltaic Panel and Examining Effects of Temperature in Matlab/Simulink. *Electronics and electrical engineering* : ISSN 1392 – 1215 2011. No. 3(109).
- [3] Nand Kishor, Marcelo Gradella Villalva, Soumya Ranjan Mohanty: Modeling of PV Module with Consideration of Environmental Factors. 2010 - IEEE PES ISGT Europe.
- [4] Huan-Liang Tsai, Ci-Siang Tu, and Yi-Jie Su:Development of Generalized Photovoltaic Model Using MATLAB/SIMULINK. WCECS 2008, October 22 - 24, 2008, San Francisco, USA.
- [5] M. G. Villalva, J. R. Gazoli, E. Ruppert F : MODELING and circuit-based simulation of photovoltaic arrays.Brazilian *Journal of Power Electronics*,2009.vol 14,no.1,ISSN 1414-8862.
- [6] F. Adamo 1, F. Attivissimo 1, A. Di Nisio 1, A. M. L. Lanzolla 2, M. Spadavecchia 1 :parameters estimation for a model of photovoltaic panels. *xix imeko World Congress Fundamental and Applied Metrology* September 6–11, 2009, Lisbon, Portugal.
- [7] A.Zegaoui, P. Petit1,'Simulation of Photovoltaic Generators and Comparison of two common Maximum Power Point trackers'. *International Conference on Renewable Energies and Power Quality (ICREPQ'10)* Granada (Spain), 23th to 25th March, 2010.
- [8] Savita Nema, R.K.Nema, Gayatri Agnihotri :Matlab / simulink based study of photovoltaic cells / modules / array and their experimental verification. *Journal homepage*. Volume 1, Issue 3, 2010 pp.487-500.
- [9] Dr. Abu Tariq, Mohammed Asim and Mohd.Tariq: Simulink based modeling, simulation and Performance Evaluation of an MPPT for maximum power generation on resistive load. IPCBEE vol.6 (2011) *IACSIT Press*, Singapore.
- [10] K.zaplatilek, J. leuchter : Behavioral Model of Photovoltaic Panel in Simulink®.*Advances in Electrical and Computer Engineering* Volume 11, Number 4, 2011.
- [11] R. Gupta, G. Gupta, D. Kastwar, A. Hussain and H. Ranjan, "Modeling and Design of MPPT Controller for a PV Module using PSCAD/EMTDC" , *M.N.National Institute of Technology*, Allahabad-2004, India.