

Control Of a Doubly fed Induction Machine for a Wind Application

Amel OURICI

Electrical engineering institute, University Badji Mokhtar Annaba
amel.ourici@hotmail.com

Abstract:

The wind energy systems using a doubly-fed induction generator (DFIG) have some advantages due to variable speed operation and four quadrants active and reactive power capabilities compared with fixed speed induction. In this article, A new Dual-Direct Torque Control scheme is developed with flux model of DFIM. It is based on the principle of a double flux orientation of stator and rotor at the same time. Indeed the main idea is to maintain stator and rotor fluxes to their nominal values The proposed method shows good results simulation.

Keywords: Doubly fed induction machine, PWM inverter, wind energy, flux orientation control

1.Introduction

In order to meet power needs, taking into account economical and environmental factors, wind energy conversion is gradually gaining interest as a suitable source of renewable energy. The electromagnetic conversion is usually achieved by induction machines or synchronous and permanent magnet generators. Squirrel cage induction generators are widely used because of their lower cost, reliability, construction and simplicity of maintenance [1]. But when it is directly connected to a power network, which imposes the frequency, the speed must be set to a constant value by a mechanical device on the wind turbine. Then, for a high value of wind speed, the totality of the theoretical power can not be extracted. To overcome this problem, a converter, which must be dimensioned for the totality of the power exchanged, can be placed between the stator and the network. In order to enable variable speed operations with a lower rated power converter . The DFIM has some distinct advantages compared to the conventional squirrel-cage machine. The DFIM can be controlled from the stator or rotor by various possible combinations. The disadvantage of two used converters for stator and rotor supplying can be compensated by the best control performances of the powered systems [3]. Indeed, the input-commands are done by means of four precise degrees of control freedom relatively to the squirrel cage induction machine where its control appears quite simpler. The flux orientation strategy can transform the non linear and coupled DFIM-mathematical model to a linear model leading to one attractive solution as well as under generating or motoring operations [1–15]. Because both stator and rotor currents in doubly fed induction machine are measurable, flux vectors can be calculated easily. We present in this paper a field orientation control for both stator and rotor fluxes It results that the stator flux oriented in q-axis becomes the active power input command from which the developed torque will be controlled, while the rotor flux assumes the reactive power input command acting the magnetizing machine system.

2. Description of the System

The proposed system is shown on figure 1:

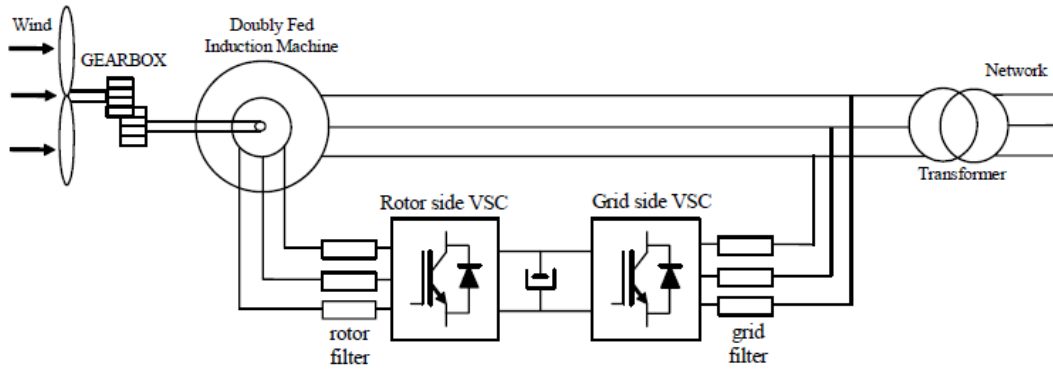

Fig .1DFIM general scheme

We choose three levels PWM for rotor inverter, it is constitute of three arms, every one has four switches formed by a transistor and a diode as shown in figure 2

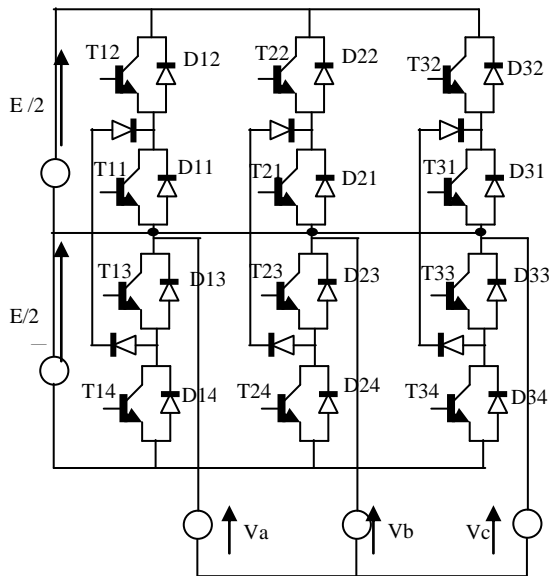

Fig .2 General diagram of a three level PWM inverter

The simple voltages are obtained starting from the following conditions:

If ($V_{ref} = V_p$) and ($V_{ref} > 0$)

$$\Rightarrow V_K = + E/2$$

If ($V_{\text{réf}} = V_p$) and ($V_{\text{réf}} < 0$)

$$\Rightarrow V_K = -E/2$$

If $V_{\text{réf}} = V_p \Rightarrow V_K = 0$

With

$V_{\text{réf}}$: reference voltage standard;

V_p : carrying;

V_K : potential of the node K.

Stator and rotor voltages of the machine after Park transformation are given by [3]:

$$\begin{cases} V_{ds} = R_s I_{ds} + \frac{d}{dt} \psi_{ds} - \frac{d\theta_s}{dt} \psi_{qs} \\ V_{qs} = R_s I_{qs} + \frac{d}{dt} \psi_{qs} + \frac{d\theta_s}{dt} \psi_{ds} \end{cases} \quad (1)$$

$$\begin{cases} V_{dr} = R_r I_{dr} + \frac{d}{dt} \psi_{dr} - \frac{d\theta_r}{dt} \psi_{qr} \\ V_{qr} = R_r I_{qr} + \frac{d}{dt} \psi_{qr} + \frac{d\theta_r}{dt} \psi_{dr} \end{cases} \quad (2)$$

Stator and rotor fluxes are given by:

$$\begin{cases} \psi_{ds} = L_s I_{ds} + M I_{dr} \\ \psi_{qs} = L_s I_{qs} + M I_{qr} \\ \psi_{dr} = L_r I_{dr} + M I_{ds} \\ \psi_{qr} = L_r I_{qr} + M I_{qs} \end{cases} \quad (3)$$

Mechanic equation is given by:

$$C_{em} = C_r + J \frac{d\Omega}{dt} + f\Omega \quad (4)$$

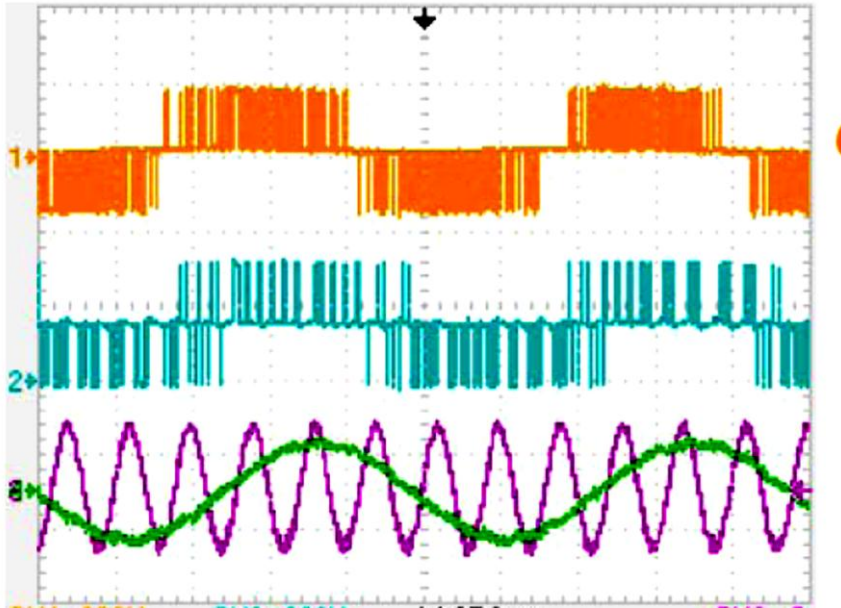

Fig .3 Vinv composed, Vinv simple, Stator and rotor currents at 1250 rpm

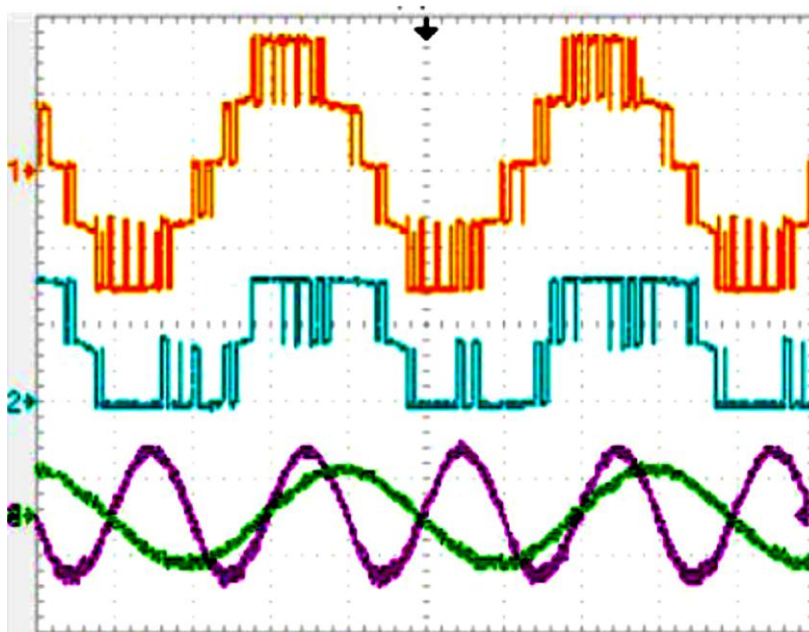

Fig .4 Vinv composed, Vinv simple, stator and rotor currents at 750 rpm

3. Double flux orientation strategy

This strategy consists to turn rotor flux towards d-axis, and stator flux towards q-axis. Conventionally, the d-axis remains reserved to magnetizing axis and q -axis to torque axis.

$$\psi_{sq} = \psi_s ,$$

$$\psi_{rd} = \psi_r ,$$

$$\psi_{sd} = \psi_{rq} = 0 .$$

Then the developed torque can be written like this

$$C_{em} = D_c \psi_s \psi_r , D_c = pM / \sigma L_s L_r$$

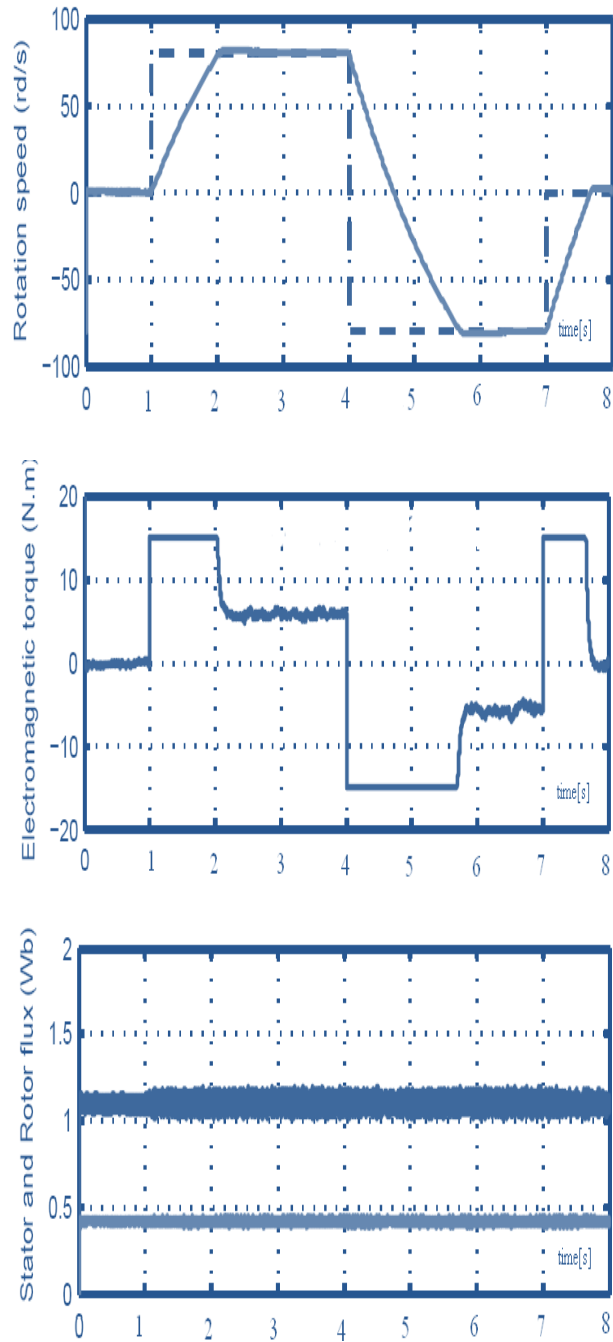

Fig 4. Speed, electromagnetic torque and stator and rotor fluxes

4.Results analysis

Figures 3 and 4 show composed and simple voltages of the three level PWM inverter, and the corresponding stator and rotor currents at two different speed of the machine. In figure 5 we can see speed, electromagnetic torque and stator and rotor fluxes after flux orientation. It can be said that this strategy in addition of its simplicity, shows good results.

5. Conclusion

We presented in this paper a simulation of a doubly fed induction machine fed with pulse width modulation inverter , based on d-q modeling. Access to the stator and rotor windings is one of the advantages of the wound rotor induction machine compared to the conventional squirrel-cage machine, consequently the doubly fed induction machine offer the several possible combinations for its control. A double flux orientation was presented , Since the fluxes are used like control variables, the machine fluxes must be maintained at acceptable level especially during the transient regimes. This strategy of control permits to give an optimal developed torque.

References

- [1] A. Masmoudi, A. Toumi & M. Kamoun, "Power analysis and efficiency optimization of a doubly fed synchronous machine", Proc. Electric Machines and Power Systems 21, pp 473-491, 1993.
- [2] Y. Kawabata , E. Ejiogu & T. Kawabata , "Vector controlled double inverter fed wound rotor induction motor suitable for high power drives IEEE Trans. Industry Applications 35 no. 5, pp 1058-1066, sept./oct 1999.
- [3] Paul Etienne VIDAL, "Commande non linéaire d'une machine asynchrone à double alimentation", Thesis of doctorate, Toulouse France, december 2004.
- [4] S.M.A. Cruz and A.J. Marque Cardoso, " Stator winding fault diagnosis in three phase synchronous and asynchronous motors , by the Extended Park's Vector Approach ", IEEE Trans on Industry applications, vol 37, No5, sept/oct 2001.
- [5] Mohamed El Hachemi Benbouzid, "A review of induction motor signature analysis as a medium for faults detection ", IEEE Trans on Industrial Electronics, vol 47 No 5, October 2000.
- [6] S. Chen and S.A. Billings, "Neural network for nonlinear system modeling and identification", Int. J. Control, vol 56, No 2, pp 319-346, Aug 1992.