

# LONG-TERM PERFORMANCE OF AN UNDERGROUND THERMAL ENERGY STORAGE SYSTEM

M.A DADA<sup>1</sup>, A. BENCHATTI<sup>2</sup>

<sup>1</sup> Laboratoire de Mécanique, University of Laghouat, B.P. 37G, Laghouat 03000, Algeria,  
dada\_abderahmane@yahoo.fr

<sup>2</sup> Laboratoire de Mécanique, University of Laghouat, B.P. 37G, Laghouat 03000, Algeria,  
a.benchatti@mail.lagh-univ.dz

## RÉSUMÉ

Thermal energy storage has received a great interest by researchers and industrials as part of designing new systems able to store and deliver thermal energy efficiently for long periods. The aim of this preliminary work is to simulate the performance of a novel seasonal heat storage system dedicated to store heat in the ground during hot period then to recover it during cold period. The system investigated herein is a ground heat exchanger buried at only 8 m below the underground. Comsol Multiphysics was used to model heat exchange between a fluid carrier flowing through a GHX, and a partially saturated porous medium. Performance of the system was evaluated for a one-year period and results showed that the use of water as a fluid carrier allowed for the storage and recovery of bigger heat energy than gasoline or glycol do. However, moisture content of the porous medium was found to not exert any influence on the whole process.

**Mots Clés:** *Heat storage, long-term, underground, heat recovery, recovery efficiency.*

---

## NOMENCLATURE

### Symbols :

A Cross sectional area of the duct, m<sup>2</sup>  
d Hydraulic diameter, m  
C Heat capacity, J/kg.K  
f Friction factor  
F Forcheimer coefficient  
G Gravity, m/s<sup>2</sup>  
k Permeability, m<sup>2</sup>  
P Pressure, Pa  
Q Heat source/sink, W/m  
T Temperature, K  
u Velocity, m/s  
V Air velocity, m/s

### Greek Letters :

$\varepsilon$  Porosity  
 $\rho$  density, kg/m<sup>3</sup>  
 $\infty$  Porous medium boundaries  
 $\mu$  Dynamic viscosity, kg/m.s  
 $\lambda$  Thermal conductivity, W/m.K

### Indexes / Exponents :

a Air  
eq Equivalent  
d Duct  
w Duct walls

---

## 1. INTRODUCTION

Underground thermal energy storage (UTES) is a sustainable technology destined to store and deliver energy at particular periods, such as winter, when heat demand is extremely high. This concept acquired a large focus because of society's energy need for heating or cooling (during summer), and to mitigate environmental issues dealing with energy production and supply. One of the UTES technology applications is seasonal storage in

porous media, which can be defined as the process of storing heat in the ground during hot season which lasts several months, and then delivering it during the cold season. Seasonal storage systems can be designed particularly in hot sunny regions to collect and store solar heat energy for later use, and the most promising applications are found underground by means of borehole heat exchangers buried in soil.

A lot of work has been carried out for studying ground heat exchangers (GHX) as part of heat storage and recovery, but only few were dedicated for the assessment of recovery efficiency or heat amount recovered during cold season. Medjelled & al (2008) conducted a set of experiments to determine thermal parameters and overall heat transfer coefficient in a sandy unsaturated porous media. Chiasson & al (2010) led a simulation study of a horizontal GHX by taking into account time-varying thermal loading and weather conditions. Lanini & al (2014) investigated a 3D numerical model to simulate different type of U-tube borehole energy storage system. Rabin & al (1991) simulated a helical GHX for purpose of long-term thermal energy storage. Diersch & al (2010) simulated arrays of borehole heat exchangers (BHE) buried at 100 m underground using finite element method (FEM). A sensitivity study performed by Welsh & al (2015) focused on the influence of some design parameters on the performance of a medium deep UTES system by means of BHE.

From what described above, it was noticed that the majority of research focused on the study of vertical GHX that go down to 100-200 m. To do differently, we chose to assess the performance of a novel GHX configuration, which is a horizontal heat exchanger buried at only 8 m below the ground. Hence, in this preliminary work, Comsol Multiphysics was used to simulate heat transfer between a multiple pass GHX and a cubic storage medium for heat storage and recovery purposes, with time-varying boundary conditions of the working fluid at the inlet of the pipes, in addition to the introduction of the atmospheric conditions such as regional temperature and wind speed during the simulation. The main goal of this work is to make a forecasting on heat energy quantity that can be stored and extracted from the UTES system according to several case studies, as well as estimating heat recovery efficiency.

## 2. DESCRIPTION DU MODELE

### 2.1. Physical system

The UTES system studied in this work as depicted in figure 1 consists of a multiple pass GHX buried in soil at a depth of 8 m. The GHX is a duct made of copper and has an internal diameter of 10 cm and a thickness of 4 mm. On the other hand, the heat storage media composed essentially of wet gravel is considered as a homogeneous and isotropic cubic porous medium having a size of 21m×20m×14m as depicted. This storage domain is covered by a 50 cm-sandy layer to minimize heat loss to the atmosphere.

Heat storage and recovery are realized during the charging and discharging processes by a hot fluid carrier flowing along a GHX buried at 8m. Performance of this heat exchanger will be evaluated according to the use of water, gasoline (organic oil) and glycol which is also used as heat carrier as well as a corrosion inhibitor. Table 1 shows physical properties of gravel while table 2 shows thermal properties for the different fluids that will be under investigation.

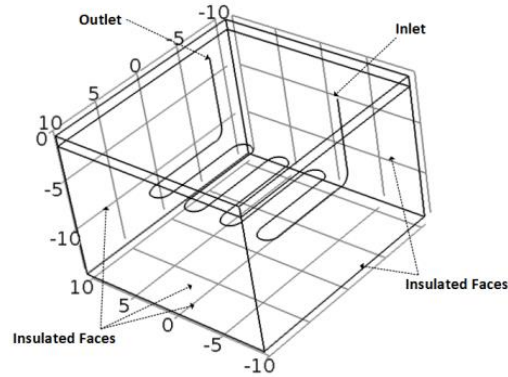

FIGURE 1. Geometry of the underground thermal energy system

Porosiy	0.47
Density (kg/m <sup>3</sup> )	2400
Thermal Concutivity (W/m. K)	2600
Specific Heat (J/kg.K)	2702

TABLE 1. Physical properties of gravel

Fluid	$\rho$ (kg/m <sup>3</sup> )	$\lambda$ (W//m.K)	$C_p$ (J/kg.K)
Gasoline	650-750	0.08-0.13	2100-3000
Water	1000	0.6	4180-4200
Glycol	1060-1130	0.252	2300-2700

TABLE 2. Thermal properties of the investigated working fluids

## 2.2. Mathematical Model

The governing equations describing the physics of heat storage and recovery process will be derived according to an unsteady mode. For the GHX, assuming a fully developed velocity profile for the working fluid and pressure drop due to viscous stress along the duct, the equations that describe heat transport and fluid flow along the duct are the following:

$$\rho \frac{d\vec{u}}{dt} = -\nabla P - \left( f_d \frac{\rho}{2D_h} \right) \vec{u} |\vec{u}| + \rho \vec{g} \quad (1)$$

$$\rho A C_p \frac{\partial T}{\partial t} + \rho A C_p u \nabla T = \nabla A \lambda \nabla T + f_d \frac{\rho A}{2D_h} |u^3| - Q_{Wall} \quad (2)$$

For the storage domain, we have considered that the system is composed of gravel - with moist air filling the void space - overlain by a sandy layer. If we consider that heat transfer inside the storage domain is solely governed by thermal conduction, and the moist air is immobile and non-reactive with the soil particles, the equation that represents transient heat transfer in a porous medium is:

$$\rho_a \frac{d\vec{V}}{dt} = -\nabla P_2 - \rho_a \left[ \frac{\mu \varepsilon}{k} + \frac{F(\varepsilon^2)}{\sqrt{k}} |\vec{V}| \right] \vec{V} + \rho_a \beta \vec{g} (T_2 - T_\infty) \quad (3)$$

$$(\rho C_p)_{eq} \frac{\partial T_2}{\partial t} + (\rho C_p)_{eq} |V| \nabla T_2 = \nabla \lambda_{eq} \nabla T_2 + Q_w + \rho_a \left( \frac{\mu \epsilon}{k} + \frac{F(\epsilon^2)}{\sqrt{k}} |V| \right) |V|^2 \quad (4)$$

The equivalent heat capacity of the medium ( $C_{eq}$ ) and the equivalent heat conductivity ( $\lambda_{eq}$ ) are taken as mean values between gravel and moist air.

### 3. RESULTS

#### 3.1. Validation

Validation process was carried out by comparing outlet temperature histories computed by our numerical model and Diersch's analytical solution. The results are displayed in figure 5 for the laminar and turbulent regimes with water as fluid carrier entering the duct at 90°C during the storing period and 10°C during the recovery period. These two plots show that our results are in good agreement with the Diersch's solution, and display the same trends.

These facts indicate that our UTES system reproduces well the physics of heat storage and recovery since Diersch's results were validated against experimental ones. Hence, good performance is to be expected in case of applying constant boundary conditions.

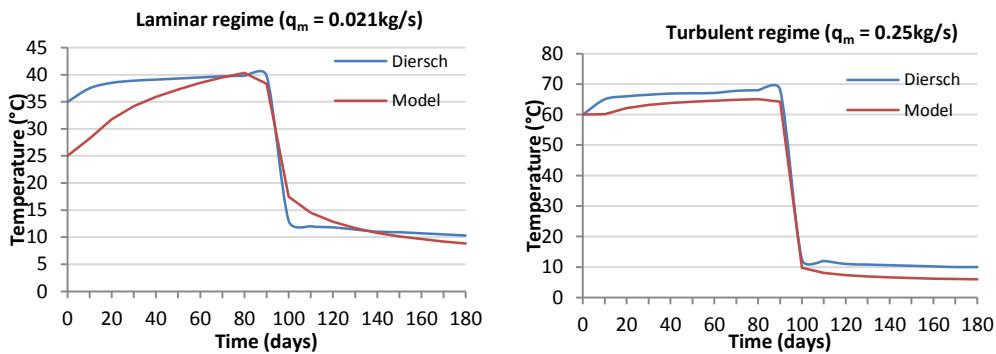

FIGURE 2. Results validation

Furthermore, it is noteworthy to say that the numerical model we set up is unable to show the same performance for daily-varying boundary conditions. This conclusion was also reported by Diersch & al (2010) who stated that daily-varying operational conditions cannot be simulated below a step-size of 10 h for laminar flow and about 4 h for turbulent flow.

#### 3.2. Thermal performance of storage and recovery

Figure 6 and figure 7 illustrate several slices of the temperature profile inside the porous medium during the charging and discharging of water. The values next to colored scale indicate the maximum and minimum temperature inside the storage medium. Most of the heat energy yielded by the water stays concentrated around the GHX while a small amount reaches the storing domain boundaries. At the end of the charging period, the maximum temperature reaches 60°C around the GHX and approximately 30°C at the boundaries of the porous medium.

On the other hand, the temperature change during the first days of discharging period is extremely fast. Until the 20th day of the beginning of this process, heat transfer between water flowing across the GHX and the storing medium is performed at a high rate, where the temperature around the heat exchanger declines from

60°C to 25°C. At the end of this period, heat transfer to the fluid carrier declines, and the temperature profile inside the porous medium ranges between 8°C and 18°C approximately.

In addition, it is essential to mention that from the simulation results, the stationary regime will be achieved at the day 144 of the discharging period where the temperature levels at the outlet of the GHX stay around 8°C.

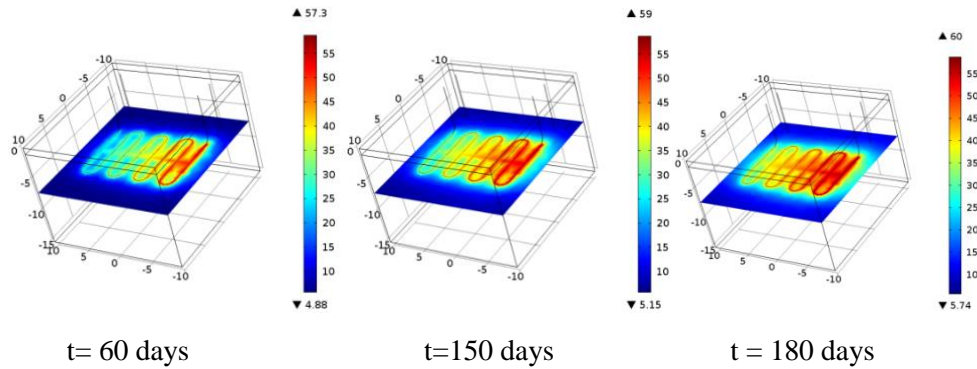

FIGURE 3. Temperature evolution during the charging period

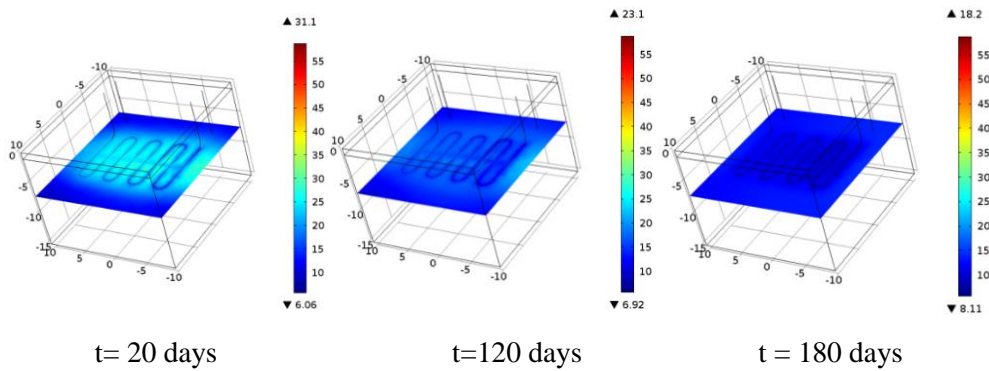

FIGURE 4. Temperature evolution during the discharging period

For both the two phases, heat exchange between the fluid carrier and the porous medium was stronger during the first days than the last days. This decline of heat exchange is primarily due the weak thermal diffusivity of the underground material, i.e. gravel, that impeached an efficient diffusion of heat to and from the porous medium. That's why a considerable amount of heat is still kept inside the domain as its temperature at the end of the recovery stage ranges between 8 and 18°C, while the temperature level delivered at the outlet of GHX, see figure 8, evolve from 25°C down to 5°C.

Consequently, as soon as the storage domain gets warmer, less heat quantity is delivered from the hot fluid carrier to the porous domain, and that's why the fluid temperature at the outlet of the GHX tends to increase with time. On the other hand, the outlet temperature of the fluid during the heat extraction period tends to decrease with time, which means that less heat is delivered to the fluid carrier as the porous domain is getting colder around the GHX, and this zone seem to act as barrier to transfer more thermal energy.

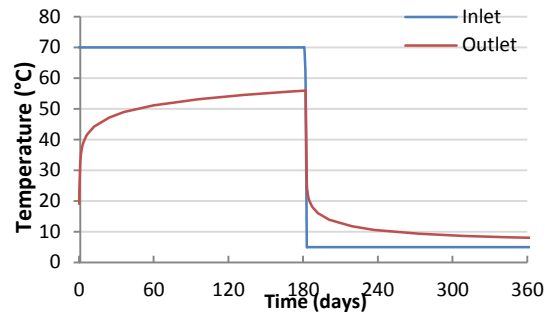

FIGURE 5. Fluid carrier temperature at the inlet and outlet of the GHX

#### 4. CONCLUSIONS

The aim of this work was to assess the performance of an innovative UTES system destined for heat storage and recovery. Several forecasting tasks were made along this paper in order to evaluate heat recovery and recovery efficiency of the system during a twelve-month period, i.e. six month of hot season for heat storage and six cold months for recovery.

All the results of this study has determined that investigating horizontal distances for heat storage purpose can be very beneficial in terms of technical and economic feasibility, having in mind the costs and technical barriers to drill deeper boreholes into the ground. It has also given us a good insight on the capabilities of this novel UTES system to show the same performance as other classical systems do.

This work will be improved in the future where we will explore other solutions to recover the amount of heat still remaining underground Furthermore, we will try to optimize the design of the UTES system studied herein and couple it with buildings or a set of houses in order to satisfy their seasonal heat energy needs.

#### REFERENCES

- [1] A. Medjelled, A. Benchatti, A. Bounif, Experimental Model for the study of heat transfer in unsaturated soil: Case of underground thermal storage, *International Journal of heat and technology*, 26, 95-102, 2008.
- [2] D. Chiasson, Modeling Horizontal Ground Heat Exchangers in Geothermal Heat Pump Systems, *Proceedings of Comsol conference*, Boston, 2010.
- [3] S. Lanini, F. Delaleux, X Py, R Olivès, D. Ngyuen, Improvement of Borehole Thermal Energy Storage Design Based on Experimental and Modelling Results Energy and buildings, *Proceedings of Energy and Buildings*, 2014.
- [4] J. G. Diersch, D. Bauer, W. Heidemann, W. Ruhaak, P. Schatzl, Finite element modeling of borehole heat exchanger systems – Part1. Fundamentals, *Journal of Computer and geosciences*, 37, 1122-1135, 2011.
- [5] J. G. Diersch, D. Bauer, W. Heidemann, W. Ruhaak, P. Schatzl, Finite element modeling of borehole heat exchanger systems – Part2. Numerical simulation, *Journal of Computer and geosciences*, 37, 1136-1147, 2011.
- [6] Y. Rabin, E. Korin, E. Sher E, A simplified model for helical heat exchanger for long-term energy storage in soil, *Proceedings of EURO THERM Seminar*, 18, 305-314, 1991.
- [7] B. Welsch, W. Ruhaak, D. O. Schulte, K. Bar, S. Homuth, I. Sass. Technical and economical evaluation of medium deep borehole thermal energy storages, 2015.